



AMERICAN HIGH VOLTAGE
POWER SUPPLIES FOR THE WORLD

G Series High Voltage Power Supply

General Description

The G Series high voltage power supplies are designed to provide very high output voltages. They provide isolated outputs of up to 50 kV with power levels to 20 Watts depending on model selected. The output voltage of the G power supply is directly proportional to the input voltage (0 – 24 VDC). The output ripple is typically less than 1% at full power load. The two output leads are floating and fully isolated from the input power leads by over 1T Ohm (@ 25 deg C). This permits either positive or negative polarity operation. All models are encapsulated in a thermosetting epoxy for high reliability. The G series are reverse input voltage and short circuit protected.



G Series

Features

- Output proportional to Input
- Encapsulated
- 5,000 VDC to 50,000 VDC available
- 20 Watts power (models under 30kV)
- Metal case for low ripple: 1% Vpp

Connection Diagram

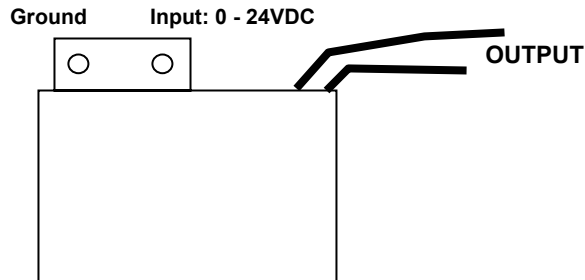

Available Models:

| Name | Maximum Output Voltage | Maximum Output Current | 1 st Year |
|-------------|------------------------|------------------------|----------------------|
| G – 5, 20W | 5,000 VDC | 4 mA | 1994 |
| G – 10, 20W | 10,000 VDC | 2 mA | 1996 |
| G – 20, 20W | 20,000 VDC | 1 mA | 1992 |
| G – 30, 10W | 30,000 VDC | 0.33 mA | 1990 |
| G – 40, 5W | 40,000 VDC | 0.13 mA | 2002 |
| G – 50, 5W | 50,000 VDC | 0.10 mA | 2006 |



AMERICAN HIGH VOLTAGE
POWER SUPPLIES FOR THE WORLD

G Series

Electrical Characteristics

(at 25 degrees C unless otherwise specified)

| Parameter | Conditions | Value | | | Units |
|------------------------|-------------------------|-------|---------|--------|---|
| | | Min | Typical | Max | |
| Supply Voltage: | (all models) | 1 VDC | 24 VDC | 28 VDC | VDC |
| Input Current: | No Load: | 155 | 175 | 180 | mA |
| | Full Load (20W models): | 1.05 | 1.1 | 1.25 | A |
| Output Ripple: | No Load (all models): | 0.5 % | 0.6 % | 0.7 % | V _{pp} |
| | Full Load (all models): | 0.8 % | 0.9 % | 1 % | V _{pp} |
| Load Regulation: | No Load to Full Load | 20% | 20% | 25% | V _{NL} /V _L |
| | Half Load to Full Load | 10% | 15% | 20% | V _{NL} /V _L |
| Output Linearity | No Load | | 1% | | $\frac{\Delta V_{OUT}}{\Delta V_{OUT (ideal)}}$ |
| Output Linearity | Full Load (all models): | | 1% | | $\frac{\Delta V_{OUT}}{\Delta V_{OUT (ideal)}}$ |
| Short Circuit Current: | | | 200 | 300 | mA |
| Power Efficiency: | Full Load | 60% | 70% | 75% | $\frac{P_{OUT}}{P_{IN}}$ |
| Reverse Input Polarity | Protected to 50 VDC | | | | |
| Temperature Drift: | No Load | | | 1,000 | ppm/DegC |
| | Full Load | | | 1,000 | ppm/Deg C |
| Thermal Rise: | No Load (case) | | | 15 | degrees C |
| | Full Load (case) | | | 25 | degrees C |
| Slew Rate (10% - 90%) | No Load | | | 100 | mS |
| | Full Load | | | 120 | mS |
| Slew Rate (90% - 10%) | No Load | | | 200 | mS |
| | Full Load | | | 100 | mS |
| Drain Out Time | No Load (5 TC) | | | 250 | mS |



AMERICAN HIGH VOLTAGE
POWER SUPPLIES FOR THE WORLD

G Series

Physical Characteristics

(at 25 degrees C unless otherwise specified)

| Parameter | Conditions | Value | Units |
|---------------------------------|---|----------------------|-------------------|
| Dimensions | MKS | 127L x 44.5W x 95.3H | mm |
| | English | 5.0L x 1.75W x 3.75H | inches |
| Volume: | MKS | 538.6 | cm ³ |
| | English | 32.8 | inch ³ |
| Mass: | MKS | 675 | grams |
| | English | 24 | oz |
| Packaging: | RTV Elastomeric | | |
| Finish | Black anodized aluminum | | |
| Terminations: Input: Output: | Electro Plated Brass terminals Flying HV leads #22 AWG | | |

Environmental Characteristics

(at 25 degrees C unless otherwise specified)

| Parameter | Conditions | Value | Units |
|-------------------|----------------------------|------------------------------|------------|
| Temperature Range | case temperature | -40 degrees to + 71 degrees | Celsius |
| | case temperature | -40 degrees to + 160 degrees | Fahrenheit |
| Shock: | MIL-STD-810 Method 516 | 40 g's | Proc IV |
| Altitude: | pins sealed against corona | -350 to + 16,700 | meters |
| | pins sealed against corona | -1,000 to +55,000 | feet |
| Vibrations: | MIL-STD-810 Method 514 | 20 g's | Curve E |
| Thermal Shock | MIL-STD-810 Method 504 | -40 deg C to + 71 deg C | Class 2 |



AMERICAN HIGH VOLTAGE
POWER SUPPLIES FOR THE WORLD

G Series Performance Charts

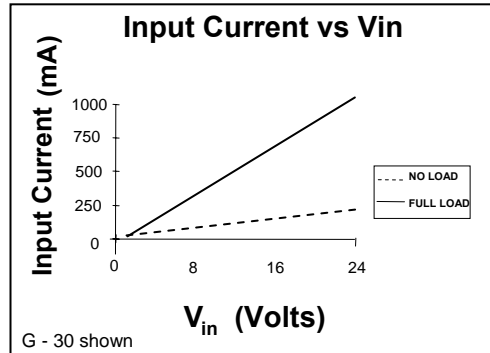
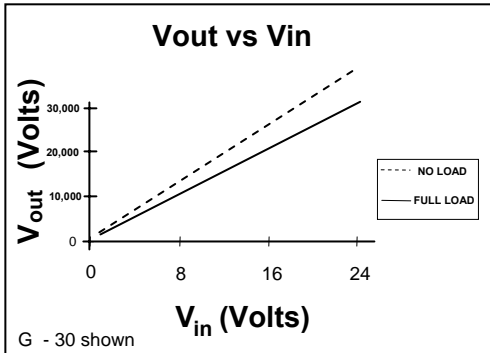

G Series Application Notes

The G Series high voltage power supplies are driven by an input voltage of 1 to 24 VDC. The input current and output voltage as a function of input is shown in the above graphs. There are NO internal connections between the input and output pins. As can be seen from the above, the output voltage is approximately linear with respect to input except near the lower input voltage region. Here, the output drops off rapidly as the input voltage approaches zero with the absolute minimum input voltage needed for reliable starting being 0.9 VDC. As shown in Figure 1 below, the simple connection of a G unit to a DC source of voltage will provide a high voltage stepped-up output. The input AC bypass capacitor C1 is optional and is utilized to prevent switching spikes from riding back on the input power lines. Values of 0.1 uF to 10 uF are commonly used.

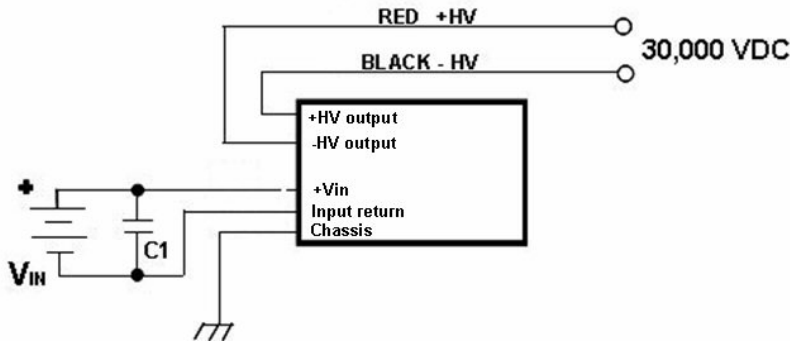

Figure 1: Basic G hookup schematic

The output voltage of the G unit may be regulated by incorporating a simple op-amp circuit and linear control device such as an NPN transistor. Here, the output voltage is sensed and compared against an external reference control voltage. For single supply operation, the circuit of Figure 2 may be used for positive output regulation. A high voltage divider is made up of R5 and R6 to divide down the output to a value comparable with the control voltage. The resistor R5 is value is determined by power considerations. A good rule of thumb is to be 10% of the full output load. Too high a value may lead to output drift problems due to operational amplifier input bias current drift. The resistor R5 must be rated for the voltage that it is to step down. Simple high value carbon film resistors are usually avoided because their maximum voltage is limited to 300 VDC. Precision metal film resistors are more stable but also have limiting maximum voltages. It is possible to series several metal film resistors to build up the voltage rating of R5. Capacitor C4 likewise must be rated for the proper voltage. It serves to lower output ripple provide a feed-forward pole in the feedback loop for stability. Capacitor C5, the ground mirror capacitor serves as a lower end of the AC divider formed with C4 and prevents excessive voltage from being fed to the operational amplifier in the case of a shorted output.



G Series Application Notes (continued)

R6 is selected by calculating the resistance divider ration with R5, providing a 5 volt feedback at full output voltage. The input reference bypass capacitor C1 is used to remove any noise feeding to the non-inverting signal pin of the operational amplifier. For maximum temperature stability, R1 should be identical in value to R6.

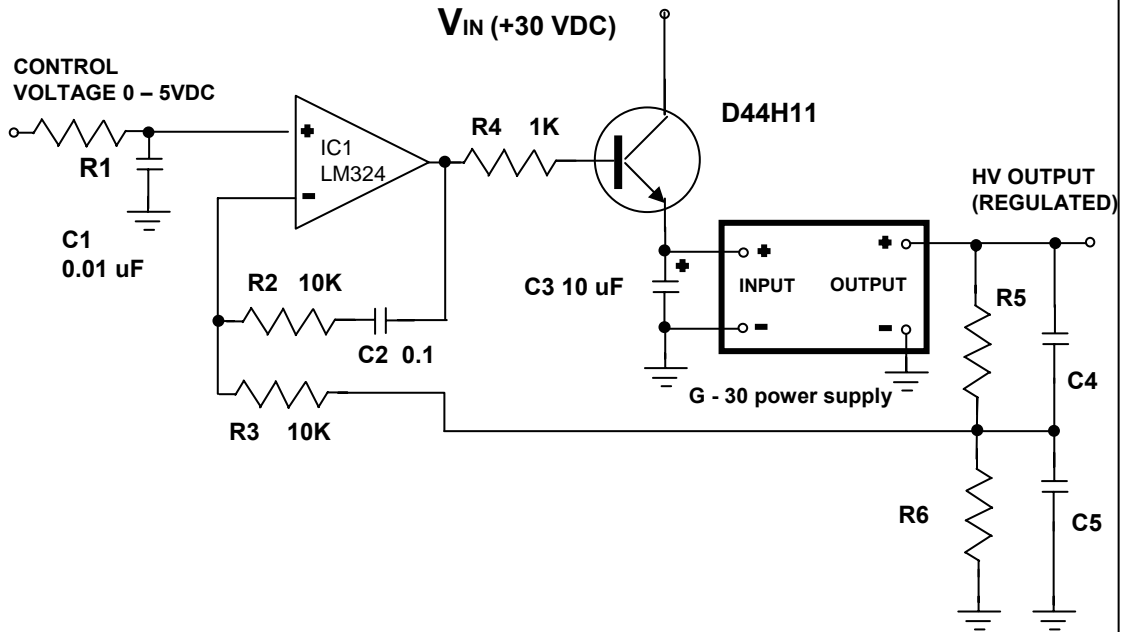

Figure 2: Positive 25,000 Volt Regulator

Resistor R2 and capacitor C2 provide frequency compensation for the amplifier IC1 a common bipolar amplifier is used since its outputs and signal inputs can reach almost to ground. R3 provides protection to the signal inverting input of the opamp in case of a short circuit or arcing condition exists on the HV output. R4 protects the output of the opamp in case of a shorted NPN transistor. Typical values for a 1,000 volt PMT supply are as follows:

| | |
|------|---|
| G: | G - 30 |
| R1: | 100K Ohm |
| R5: | 500 Megohms (Slimox 104 – Ohmite two 250 M in series) |
| R6: | 100K Ohm |
| C4: | 1,000 pF 30kV disc |
| C5: | 0.1 uF 100 V ceramic |
| IC1: | LM324 |
| Q1: | Power NPN such as D44H11 or equivalent |

Typical voltages seen during operation are as follows:

| | |
|-----------------------------------|--|
| Voltage at junction of R5 and R6: | 5V |
| Voltage at opamp output: | 20.2 V |
| Voltage into + supply G: | 19 V (depends somewhat on output load) |
| Voltage of base of Q1: | 20.9 V |

The power supply feeding the opamp is not shown however it may be connected to the +30 V supply and ground. This allows an output from the power NPN transistor to be approximately 20 volts maximum. This is sufficient head room to allow 25,000 VDC from the G-30 power supply. It is always a good idea to bypass the input power pins of the opamp with a 0.1 uF capacitor to reduce the EMI that may damage the opamp if an output arcing condition is suddenly encountered.



AMERICAN HIGH VOLTAGE
POWER SUPPLIES FOR THE WORLD

G Series Application Notes (continued)

By varying the control voltage from 1 to 5V, the high voltage output of the G power supply may be regulated. Line and load regulation as good as 0.01% are achievable depending upon physical layout and quality of feedback resistor. To lower the output ripple further, a resistor (carbon composition type) of a high value may be inserted in series with the HV output of the G unit before it continues on in the circuit. A value of 200K Ohm will drop the output ripple to less than 0.1%. Here the 200 K Ohm resistor works as a filter in conjunction with C4. Higher ripple reduction is achievable with a capacitor added directly to the output pin and ground.

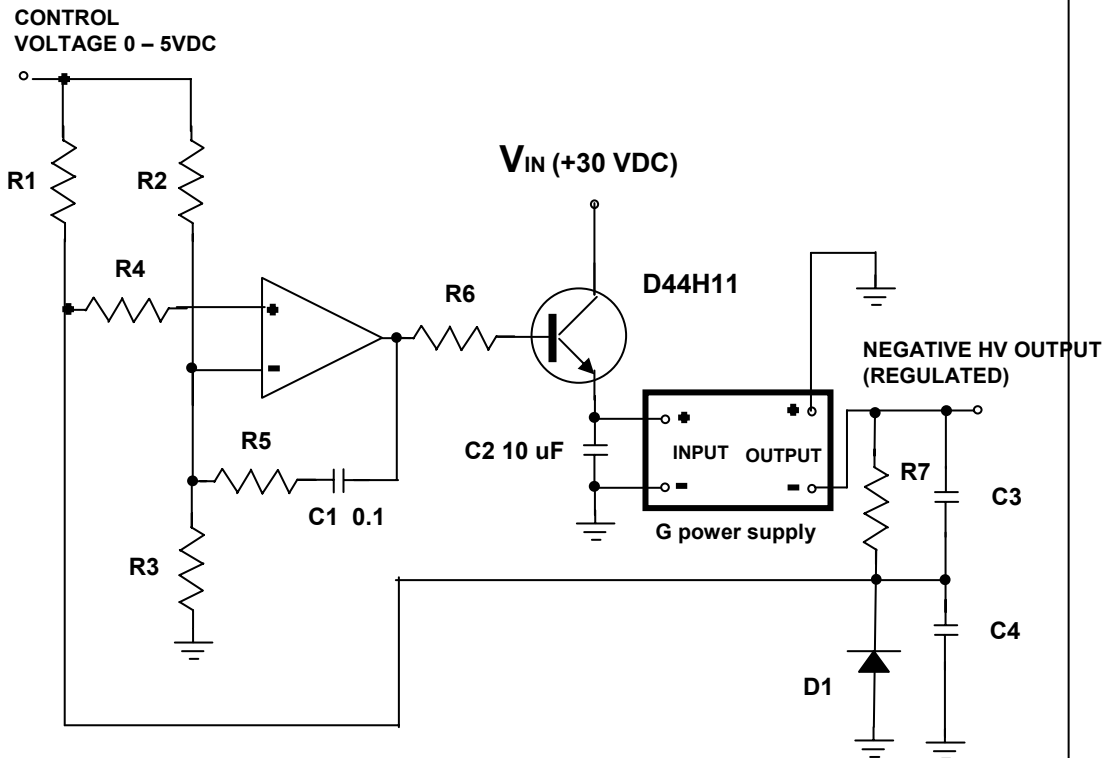

Figure 3: Negative 15,000 Volt Regulator

A regulated negative High Voltage output is easily obtained using the floating output feature of the G unit. Figure 3 utilizes much of the same topology as the positive regulator except that a summing junction is made for operational amplifier IC1. Again, the values of R7 and C3 are selected with respect to the proper HV output parameters. Dissipation in R7 should be limited to less than 10% full load. C3 must be a high voltage capacitor, capable of working at the full output voltage. Diode D1 provides a return path in cast the output is suddenly shorted, protecting IC1 from huge positive spikes on the signal input. Resistors R2 and R3 form a simple divider, their values should be equal. The voltage drop in R1 should be such that at full output voltage the signal at the non-inverting input of IC1 should be exactly half the control voltage. R4 is a simple 10K Ohm limiter. The values of R2 and R3 should be twice that of R1 for good thermal stability. Typical values for a negative 15,000 volts negative output electrostatic precipitator power supply are as follows:

| | | | |
|-----|-----------------------------------|------|--------------------------|
| G: | G - 20 | R5: | 10K |
| R1: | 33.3 K Ohm | C3: | 1,000 pF 20kV disc |
| R7: | 200 Megohms (Slimox 104 – Ohmite) | C4: | 0.1 uF 100 V ceramic |
| R2: | 66.6K Ohm | IC1: | LM324 |
| R3: | 66.6K Ohm | Q1: | Power NPN such as D44H11 |



AMERICAN HIGH VOLTAGE
POWER SUPPLIES FOR THE WORLD

G Series

Equivalent G Circuit Model

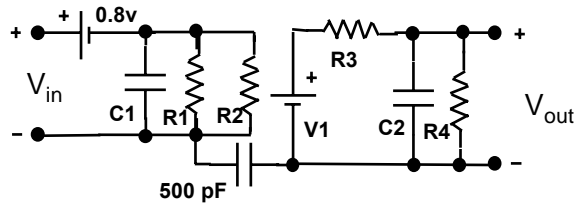

Equivalent G HVPS Circuit Model

- R1 = (137) Ohms
- R2 = (520 / Pout) Ohms
- R3 = (0.2 x Vout_{max} / Iout_{max}) Ohms
- R4 = (1 x Vout_{max}²) Ohms
- C1 = (10 x 10⁻⁶) Farads
- C2 = (0.01 x Iout_{max} / Vout_{max}) Farads
- V1 = (VR2 x Vout_{max} / 24) Volts

For example, for an G - 20

- Vout_{max} = 20,000 V
- Pout_{max} = 20 W
- Iout_{max} = 0.001 A
- R1 = 137 Ohms
- R2 = 26 Ohms
- R3 = 4 Megohms
- R4 = 200 Megohm
- C1 = 10 uF
- C2 = 500 pF

Outline Drawing: (inches (millimeters))

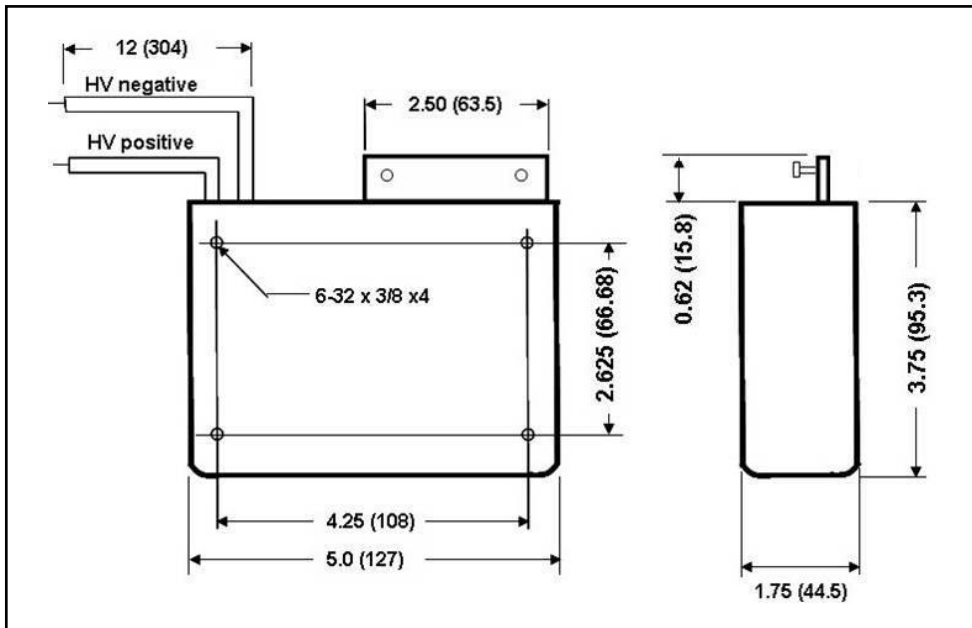

Ordering Information:

G - XX

Example:

- G - 30: Maximum output = 30,000 V
- G - 20: Maximum output = 20,000 V

- XX = Output voltage
- 5 = 5,000
- 10 = 10,000
- 20 = 20,000
- 30 = 30,000
- 40 = 40,000
- 50 = 50,000